

Installation instructions for TDS p/n 200170 1983-92 F-Body Greasable Front Sway Bar Bushings

CAUTION: WHEN WORKING UNDER A CAR, ALWAYS BE AWARE THAT THERE IS A HEAVY VEHICLE ABOVE YOU. REGARDLESS OF LIFTING METHOD USED, THE REAR WHEELS SHOULD BE CHOCKED OR BLOCKED. TRANSMISSION IN PARK (IF AUTOMATIC) OR REVERSE (IF MANUAL) AND PARKING BRAKE SET. THE VEHICLE SHOULD BE ON A LEVEL SURFACE SUFFICIENT TO SUPPORT THE JACK AND JACK STANDS OR RAMP. A CONCRETE SURFACE IS PREFERABLE TO AN ASPHALT ONE. ASPHALT WILL SOFTEN WITH HEAT AND COULD ALLOW THE JACK, JACK STAND OR RAMP TO SETTLE. NEVER RELY SOLELY ON A HYDRAULIC JACK TO SUPPORT THE VEHICLE. LIFT THE VEHICLE WITH THE JACK, THEN USE JACK STANDS TO SUPPORT THE VEHICLE. REFER TO THE OWNER'S MANUAL FOR THE JACK STANDS OR RAMPS FOR FURTHER CAUTIONS AND INSTRUCTIONS. DO NOT USE THIS PRODUCT IN ANY WAY OTHER THAN DIRECTED OR ON ANY CAR OTHER THAN A 1983-92 F-BODY. THIS KIT WILL NOT FIT THE 1982 MODEL YEAR OR 1989 TTA (TURBO TRANS-AM).

Kit contents:

- (2) Zinc plated brackets
- (4) Zinc plated mounting bolts
- Installation Instructions
- "-32" includes a pair of modified 32mm Guldstrand Motorsports bushings
- "-34" includes a pair of modified 34mm Guldstrand Motorsports bushings
- "-36" includes a pair of modified 36mm Guldstrand Motorsports bushings
- "-CB" includes a pair of modified customer supplied bushings
- "-NB" includes no bushings

**GULDSTRAND
MOTORSPORTS**

Tools needed:

15 mm socket or wrench, large standard screwdriver or pry-bar.

Installation:

1. Verify the contents of the kit.
2. Spray the threads of the old bolts (item 1) with a thread lubricant such as WD40 or Liquid Wrench. If heavily rusted, allow it to penetrate before attempting to remove the bolts.
3. Remove the 4 bolts with a 15mm socket wrench. If it is difficult spray again with thread lubricant and use a breaker bar.
4. Remove the old brackets and bushings. It may be necessary to pry the bracket free from the frame with a large standard screwdriver or pry-bar.
5. If there is rust scale on the sway bar in the bushing mount location, clean it off. The surface must be smooth and clean for the bar to rotate correctly in the bushing.
6. Lubricate the ID of the bushing with an even coating of grease.
7. Twist open the new sway bar bushing (item 5) and install it onto the sway bar with the slit facing forward.
8. Reinstall the bolts (item 1) through the holes in the brackets (item 2) and thread them into the frame a few turns by hand. Make sure that none of the bolts are cross-threaded. Tighten the bolts and torque them to 37 ft.-lbs. (50 Nm).
9. Using a grease gun, lubricate the bushings with synthetic or marine-grade grease until grease pushes out the side of the bushing. Wipe off any excess grease and snap on the protective cap. TDS recommends Energy Suspension Formula 5 Prelube or VALVOLINE Synpower Synthetic Grease.

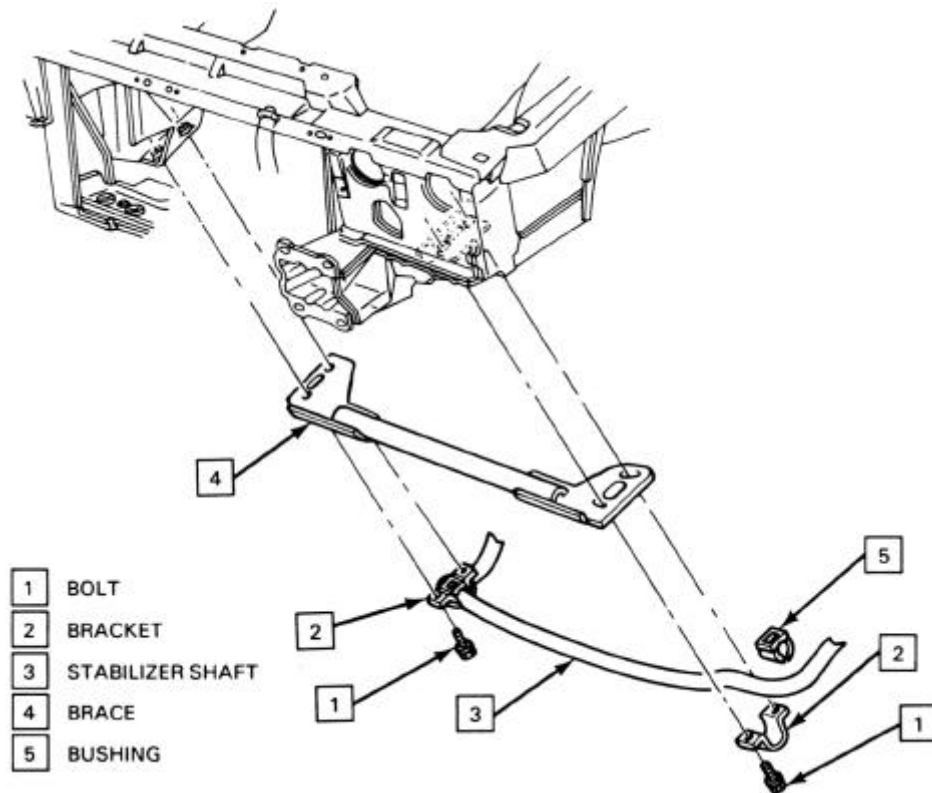

Figure 1

Additional items to consider:

Figure 1 above shows an item 4 called a "Brace". This is a Steering Brace (aka Wonder Bar). GM installed these on 1985-90 Camaro IROC-Z when equipped with the 16" diameter rims. The Steering Brace performs two functions. First it ties the left and right sides of the frame together under the front of the car, which maintains the correct geometry of the pitman arm and idler arm during cornering. Second, the Steering Brace strengthens the chassis and takes stress off of the steering gear box mount. It is common in ThirdGen F-Bodies for fatigue and stress cracks to form around the steering gear box mounting location. Installing a Steering Brace will help tighten up the front end and prevent stress cracks from occurring. GM has recently discontinued their Steering Brace. Top-Down Solutions makes a Steering Brace (p/n 105021) for the 1983-92 F-Bodies.

Another item which complements this kit is the TDS p/n 106101 Grease fitting covers. These keep the grease fittings free from dirt and debris between lube jobs. A pack of 10 covers will be enough for all 9 grease fittings that on the front suspension of a ThirdGen F-Body. The covers are available in black, blue or red. Contact us if you want to order either of these items.



p/n 200170

**Descr: Greasable Front Sway Bar Bushings
for 1983-92 F-Bodies**

Qty: 1 kit



Thank you for purchasing this item from
Top-Down Solutions.
PO Box 5601, Hacienda Heights, CA 91745
(626)369-0040, (626)369-0997 (fax)
topdownsolutions@yahoo.com

This document was printed on GP Eureka!
Recycled copier paper
(50% post consumer content).



RECYCLED SYMBOL
Used to denote products
containing recycled materials



RECYCLABLE SYMBOL
Used to identify materials
that are suitable for recycling

rev. 8/19/02